

Imaging and Video Solutions for Smart Embedded Vision

Summary

Smart Embedded Vision is opening up new possibilities for implementing systems that rely on visual data to make decisions across a broad spectrum of applications. Drones, machine vision, thermal imaging, gaming, video surveillance, robotics, Advanced Driver Assistance Systems (ADAS), machine learning and HMI all rely on cameras and displays that demand low power while supporting high-speed interfaces as well as security in data, and in design so that IP is protected. The inherent parallel processing and high-speed I/O capabilities of FPGAs makes them ideal processing platforms for delivering the high data throughputs needed for both high-resolution imaging and machine learning algorithms.

Microchip provides FPGA imaging and video solutions to enable the evaluation of multiple protocols and the development of a host of image and video processing applications. As a best-in-class imaging and video platform, Microchip's solutions come with a complete ecosystem, including comprehensive application-specific hardware, optimized intellectual property suite for image processing, sample reference designs, demonstration designs and collateral.

Microchip's award-winning PolarFire™ FPGAs are ideal for mid-bandwidth (4K/2K) imaging/video applications due to their rich memory and digital signal processor (DSP) resources in addition to offering up to 50 percent lower power than competing static random-access memory (SRAM)-based devices. The solution is also supported by Microchip's SmartFusion®2 that integrates a 166 MHz Arm® Cortex®-M3 processor and IGLOO®2. Both these families are optimal for low resolution applications with embedded Flash, PCIe Gen2 support, highest I/O density, Flash security and exceptional reliability.

SmartFusion®2 Advanced Dev Kit with Imaging FMC

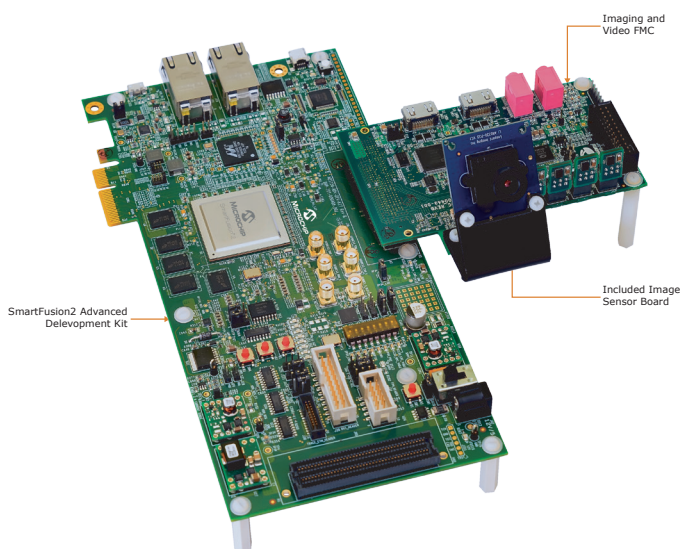

PolarFire® Video Kit

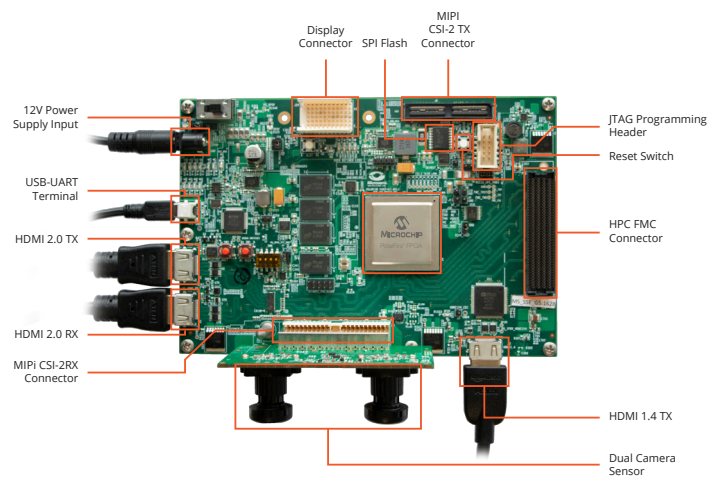

Target Applications

- Machine learning
- Automotive
- Surveillance
- Machine vision
- Drone imaging
- Medical imaging

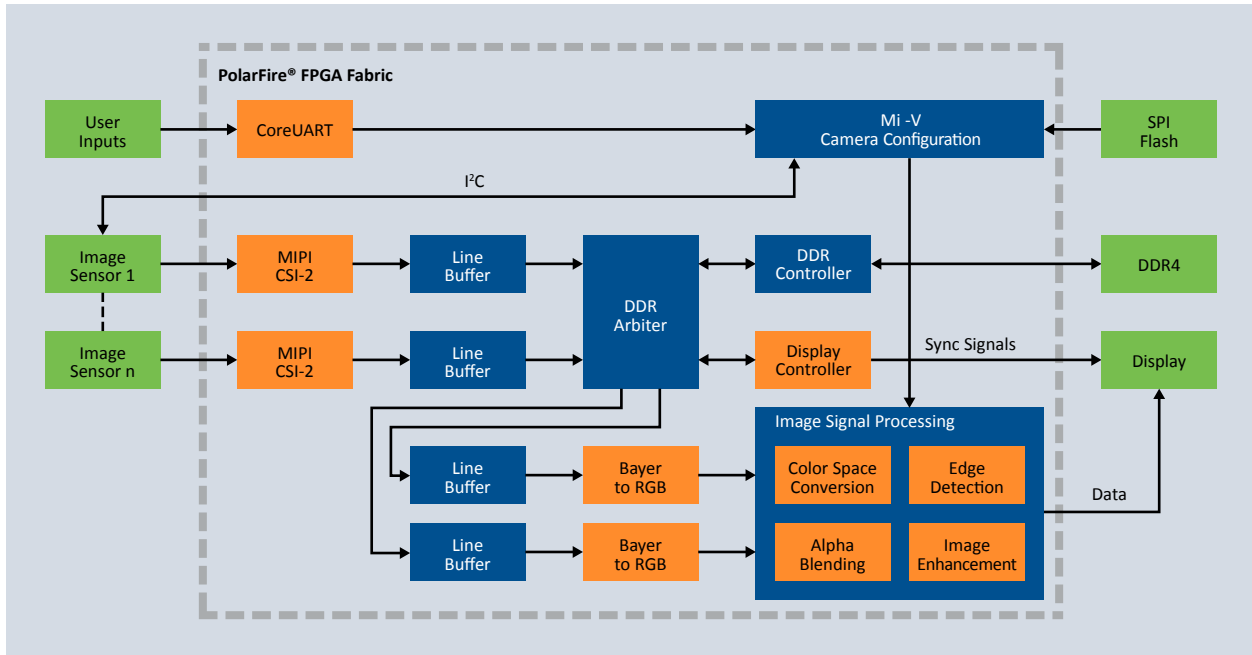

Extensive Demonstrative Designs

- Picture-in-picture with two cameras
- Edge detection
- Alpha blending, brightness, contrast, color balance ISP
- 4K resolution with third-party HDMI2.0 IP

Hardware Development Platforms

PolarFire Video and Imaging Kit

- 300K LE PolarFire FPGA in an FCG1152 package
- Sony dual camera sensor for stereo vision applications
- MIPI CSI2-RX @ 1.0 Gbps
- MIPI CSI2-TX @ 800 Mbps
- 4GB DDR4 @ 1.6 GBps
- HDMI 2.0 (4K @ 60fps), HDMI 1.4 (UHD @ 60fps)
- 3G/HD SDI, DSI, CSI-2 TX connector

SmartFusion2 Advanced Development Kit

- SmartFusion2 SoC FPGA 150K LE M2S150TS-1FCG1152
- MIPI CSI-2 sensor FMC: VIDEO-DC-MIPI
- Parallel sensor FMC: VIDEO-DC-PRL

Comprehensive IP Suite

The IP suite supports PolarFire, SmartFusion2, IGLOO2 and radiation-tolerant RTG4 product families.

- Sensor interface—MIPI CSI-2, Parallel
- Bayer conversion
- Video scaler
- Color-space conversion
- Alpha blending and overlay
- Image-edge detection
- Image enhancement
- Display control (LVDS and parallel RGB-HDMI)
- Source code in Verilog and VHDL* (requires licensing fee)

Available from our partners: HDMI2.0, HDCP 2.2, Display Port 1.4, SLVS, H.264, JPEG 2000, JPEG and JPEG-LS compression and CODEC cores.

*Verilog is only supported on source code for the SmartFusion2/IGLOO2 based solution.

Intuitive Software GUI

Enables Video and Audio Configurations

- Source selectable picture-in-picture menu
- Alpha blending and overlay
- Image edge detection and enhancements - color balance, brightness, contrast

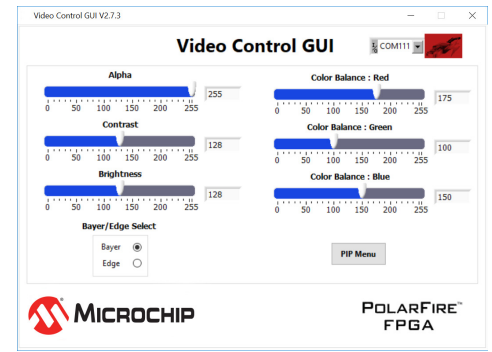
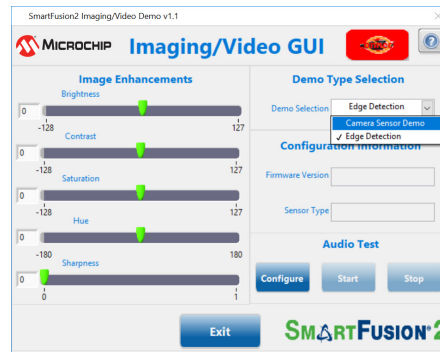

Which Device Family Best Suits Your Imaging Application?

Feature	PolarFire™	SmartFusion®2/IGLOO®2
Performance	<ul style="list-style-type: none"> • Transceivers@12.7G, DDR4@1.6G, CSI-2 Rx@1.0G, LVDS@1.6G • 1657 GMAC/s Max DSP Performance 	<ul style="list-style-type: none"> • Transceivers@5G, DDR2/3@0.667G, LVDS@0.7G • Targets lower resolutions
Resolution	Up to 4K (3840 x2160)	Up to HD (1280 x 720)
Protocol Support	MIPI CSI-2 (RX, TX),HDMI 2.0 ,3G SDI,DSI	MIPI CSI-2 (RX),HDMI 1.4
Speed and Frame Rate	<ul style="list-style-type: none"> • MIPI: RX at 4.8 Gbps (4 x 1.0 Gbps), TX at 3.2 Gbps (4x 800 Mbps) • 4K @ 30 fps 	<ul style="list-style-type: none"> • MIPI: RX only up to 700 Mbps, HS mode only • HD @ 30 fps

Ordering Information

Microchip Video and Imaging Solution	Product Order Code
PolarFire® Video Kit	MPF300-VIDEO-KIT
SmartFusion® 2 Advanced Development Kit	M2S150-DEV-KIT
Imaging and Video card with MIPI CSI-2 sensor module	VIDEO-DC-MIPI
Imaging and Video card with parallel sensor module	VIDEO-DC-PRL
Imaging and Video IP Suite RTL source	VDSOLCores-RM and VDSOLCores-RMFL